

Application for temporary food stall licence

Authorising Provisions
Food Act 2006
(Chapter 3)

If you have any specific enquires regarding this application please contact Council's Licensing & Approvals Section on (07) 5581 6668 or Fax: (07) 5581 6898.

Please complete this application in BLOCK LETTERS, tick boxes where applicable and attach required further information.

Collection Notice: Council requires the personal information requested on this form for the purpose of assessing your application and administering licenses and approvals in the city. The information will not be disclosed to any other party unless required by law.

<p>Application must be received a minimum of 14 working days prior to event</p>	<p>Term of Licence</p> <p><input type="checkbox"/> One-off event - \$ 84.00 (one day)</p> <p><input type="checkbox"/> Annual licence (expiring 31 August next) \$500.00</p> <p>Please tick <input checked="" type="checkbox"/> the appropriate selection</p>
<p>Applicant must be a legal entity (e.g. Individual/s, trustee/s, company – not business or trading name)</p>	<p>Applicant details</p> <p>Applicant Name: _____ <small>(e.g. Individual/s, trustee/s, company)</small></p> <p>ABN: _____ ACN: _____</p> <p>Postal address: _____ _____</p> <p>Trading name: _____</p> <p>Registered business address: _____ _____</p> <p>Contact person: _____</p> <p>Phone no.: _____ mobile no.: _____</p> <p>Fax no.: _____</p> <p>Email address: _____</p>
<p>Details of where stall is proposed to be exactly located.</p> <p>If more space is required please attach information to application</p>	<p>Location & event details</p> <p>Date/s of event: _____</p> <p>Name of event/s _____</p> <p>Address of event/s _____</p> <p>Stall site number (if applicable) _____</p> <p>Proposed duration of event: days _____ times _____</p> <p>Type of event: <input type="checkbox"/> Indoor <input type="checkbox"/> Outdoor</p> <p>Trading name _____</p>

Contact person name: _____

Phone _____ mobile _____ fax _____

Email: _____

Please Note: If you are proposing to operate your food stall on council controlled land you may required approval of the use of the land

Description of food stall

Plans of the site layout will be required to be submitted. If not provided may delay approval process.

Type of food or processing: _____

Supporting information on

- Temperature control
- Food storage area dry /hot /cold
- Water supply, including hot water supply
- Walls, roof and floor (i.e. materials)
- Refuse storage areas
- Finishes to benches, tables
- Washing facilities (hand and utensils)
- Waste water disposal
- Power supply
- Protection from contamination
- Food preparation and display areas
- Storage and handling conditions of food prior to and including delivery/transport of food to the market and point of sale i.e. storage containers, temperature

Check list

- two copies of floor plan
- the floor plan should also indicate the type of materials and finishes used on equipment, fixtures, fittings, floors, walls and ceilings
- potable water and waste water holding tanks and drainage outlets etc sink details and dimensions
- two copies of food transport vehicle plan (if vehicle is to be used drawn to scale)
- correct fee / no fee
- name of directors of company
- copy of food licence certificate of permanent premise

Food Safety Supervisor

Please provide details of your nominated food safety supervisor for the licensable food business.

Full name: _____

Postal address: _____

Phone: B/H _____ Mobile _____

e-mail: _____

	<p>Qualifications/skills and knowledge</p> <hr/> <hr/> <hr/> <p>Please note: If you do not know the details of your food safety supervisor(s) at this time, do not complete this section. This will not affect the decision made on your application. However, you are required to provide the details of your food safety supervisor(s) within thirty (30) days of receiving your licence</p>															
<p>A corresponding law includes a law applying, or that applied, in the Commonwealth, another State, a Territory, or a foreign country.</p>	<p>Suitability of applicant/licensee</p> <p>Has the applicant ever had a licence refused, suspended or cancelled, or been convicted of an offence (other than a spent offence) under the <i>Food Act 2006</i>, <i>Food Act 1981</i> or a corresponding law in other states or territories?</p> <p>(If the applicant is a corporation or an incorporated association, an executive officer of the corporation or a member of the associated incorporation's management committee, are included).</p> <p><input type="checkbox"/> No <input type="checkbox"/> Yes → attach full details</p> <p>Please provide details of skills knowledge the applicant has to sell safe and suitable food. Alternatively provide details for the person providing this service to the applicant.</p> <hr/> <hr/>															
	<p>Signature of applicant</p> <p>I/We, _____ certify that the above information and the information on any attachments, to the best of my knowledge, is true and correct.</p> <p>Signature of applicant: _____ Date ___/___/___</p>															
<p>Disclaimer: Should approval be given to this application such approval will not extend to approving any other statutory or Local Government requirements relating to the premises.</p>																
<p>Fees</p>	<p>Is the stall directly associated with premises holding a current food licence within Gold Coast City Council?</p> <p><input type="checkbox"/> Yes → No fees apply. Please specify name and licence number of associated food business: _____</p> <p><input type="checkbox"/> No → Fees may apply (see below).</p> <p>The following licence fees (yearly) are required for businesses whose operations are based outside the City of the Gold Coast:</p> <table border="1" data-bbox="331 1637 1501 1809"> <thead> <tr> <th>Application lodged in the period:</th> <th>Payable fee</th> <th>Licence</th> </tr> </thead> <tbody> <tr> <td>1 September to 30 November</td> <td>Full fee</td> <td>\$500.00</td> </tr> <tr> <td>1 December to last day February</td> <td>75% fee</td> <td>\$375.00</td> </tr> <tr> <td>1 March to 31 May</td> <td>50% fee</td> <td>\$250.00</td> </tr> <tr> <td>1 June to 31 August</td> <td>25% fee</td> <td>\$125.00</td> </tr> </tbody> </table> <p>For further clarification please contact Council's Licensing & Approvals Section on (07) 5581 6668 or visit Council's website at goldcoastcity.com.au</p>	Application lodged in the period:	Payable fee	Licence	1 September to 30 November	Full fee	\$500.00	1 December to last day February	75% fee	\$375.00	1 March to 31 May	50% fee	\$250.00	1 June to 31 August	25% fee	\$125.00
Application lodged in the period:	Payable fee	Licence														
1 September to 30 November	Full fee	\$500.00														
1 December to last day February	75% fee	\$375.00														
1 March to 31 May	50% fee	\$250.00														
1 June to 31 August	25% fee	\$125.00														
<p>Office use only</p>	<table border="1" data-bbox="331 1906 1501 1966"> <tr> <td>Receipt no:</td> <td>Date:</td> </tr> </table> <p>Licence (one-day event) LI NB TFS \$ _____ Licence LI NB TFS \$ _____ Licensing & Approvals Only: LI NB TFS DATE: _____</p>	Receipt no:	Date:													
Receipt no:	Date:															



Gold Coast City Council

ARTISTS IMPRESSION – MINIMUM STANDARDS FOR THE OPERATION OF A TEMPORARY FOOD STALL

Ensure a minimum distance of 10 metres separates food operations and any areas that are accessed by animals

Display of current Certificate of Food Hygiene Licence and Registration for temporary food stall

Food display, Food protection, Taste Testing - see over

Refuse Bin with lid and liner supplied

All food prepared inside stall. No food stored directly on ground. Overall clean condition.

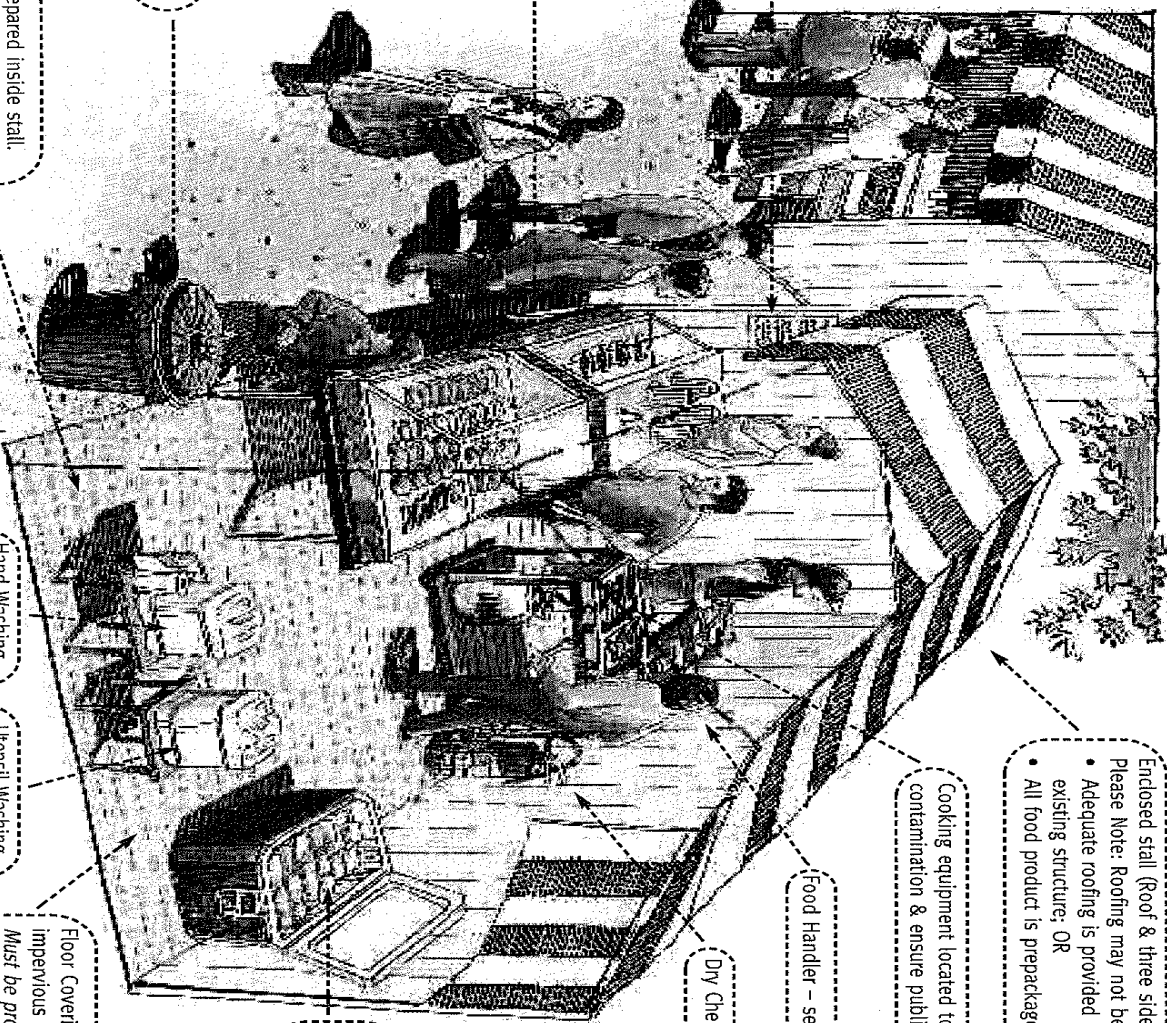

Enclosed stall (Roof & three sides)
Please Note: Roofing may not be required where:
• Adequate roofing is provided when located within an existing structure; OR
• All food product is prepackaged (no taste testing)

Cooking equipment located to protect food from contamination & ensure public safety

Food Handler – see over

Dry Chemical Fire Extinguisher

Temperature Control for potentially hazardous and perishable foods - see over

Floor Covering – easy to clean, impervious material. **Please Note:** Must be provided if located on unsealed ground.

Hand Washing Facility - see over

Utensil Washing Facility - see over

Produced by ECDC Publications Unit 2003 © 2007

Minimum hand washing facilities

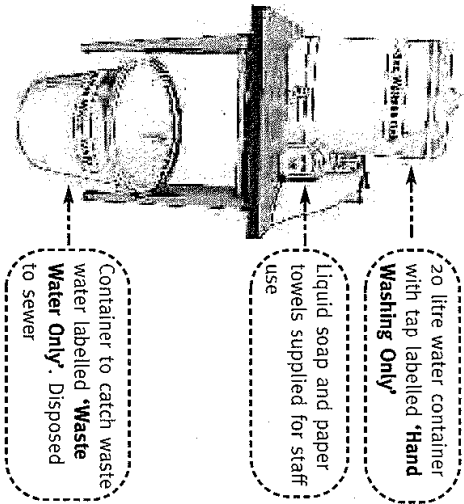

Minimum utensil washing facilities

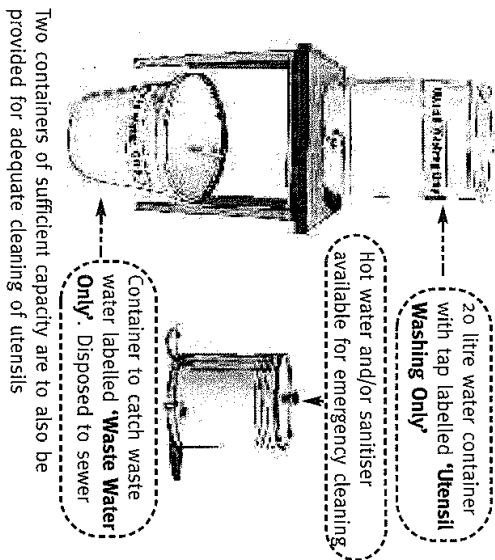

Food Handlers

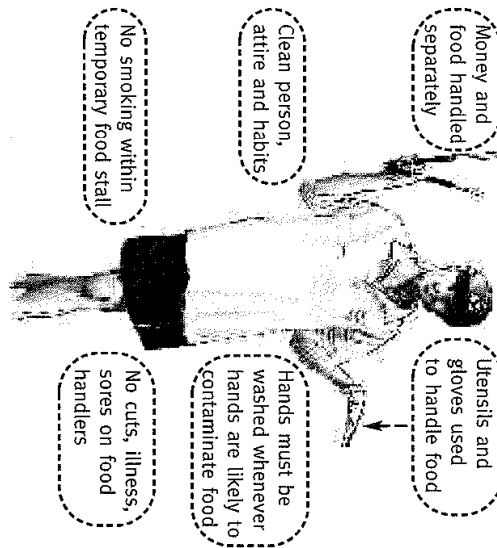

Food display, food protection, taste testing

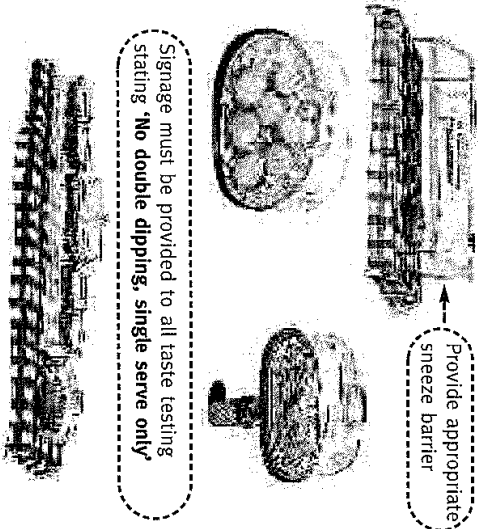

Sauces, condiments and single serve utensils

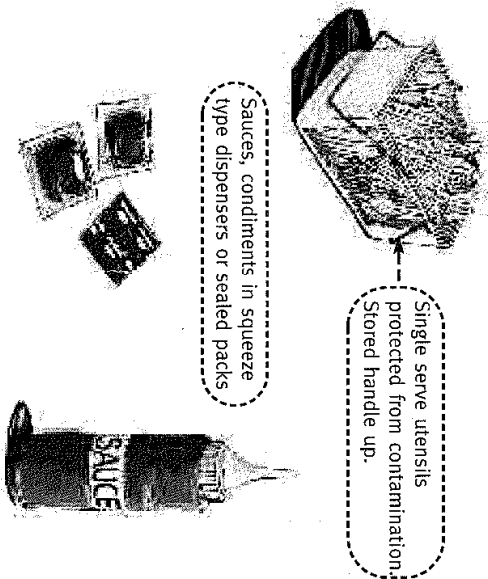

Temperature control of potentially hazardous food

