

**DUNE PROTECTION FENCE**

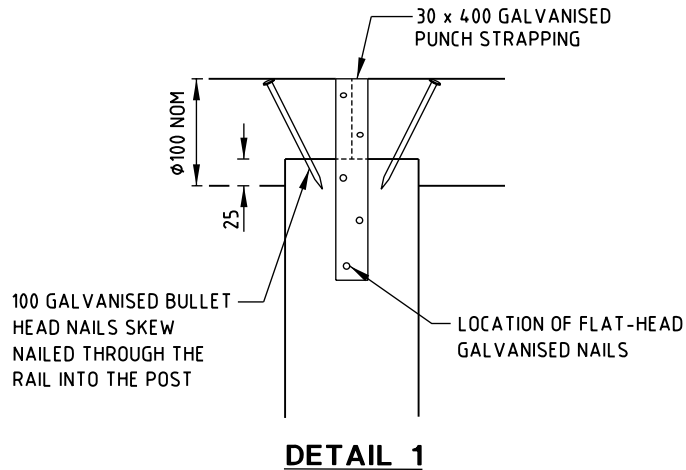

**DETAIL 1**

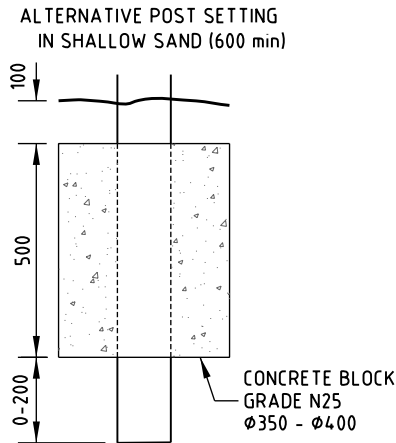

**DETAIL 2**

**NOTES:**

1. STAPLES SHALL BE LOCATED AT 90° TO THE TIMBER GRAIN.
2. KNITTED GREEN SHADE FABRIC SHALL BE LOCATED AND STAPLED ON THE SEAWARD SIDE OF THE FENCE.
3. ALL DIMENSIONS ARE IN MILLIMETRES UNLESS SHOWN OTHERWISE.

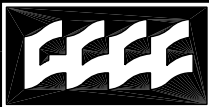

**Gold Coast City Council**  
 GOLD COAST CITY COUNCIL  
 PO BOX 5042  
 GOLD COAST MC 9729

THIS DRAWING IS NOT TO BE AMENDED WITHOUT REFERENCE TO STANDARDS COMMITTEE				CONTROLLED DOCUMENT	DO NOT SCALE TAKE FIGURED DIMENSIONS ONLY	STANDARD DRAWING	MICROFILMED
No.	AMENDMENT	APPROVED	DATE	ISSUED	DRAWN BY TECHNICAL SERVICES BRANCH	<b>DUNE PROTECTION FENCE</b>	STANDARD DRAWING No. <b>05-04-003</b>
					PASSED <i>[Signature]</i> 18/03/04		ISSUE
					APPROVED <i>[Signature]</i> 18/03/04		2005 EDITION

--	--	--	--	--	--

--	--	--	--	--	--

--	--	--	--	--	--