

LOCK BOX TOP VIEW

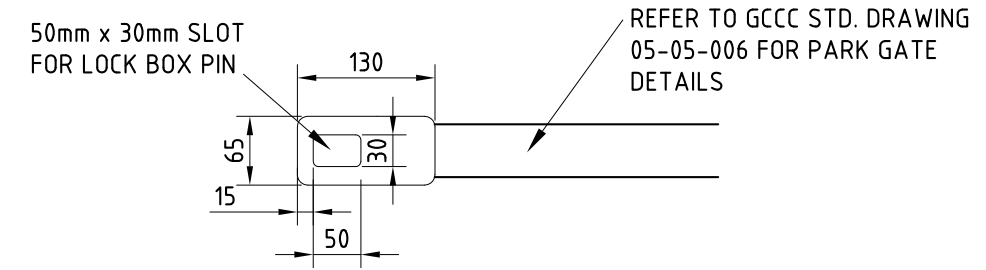

TONGUE TOP VIEW

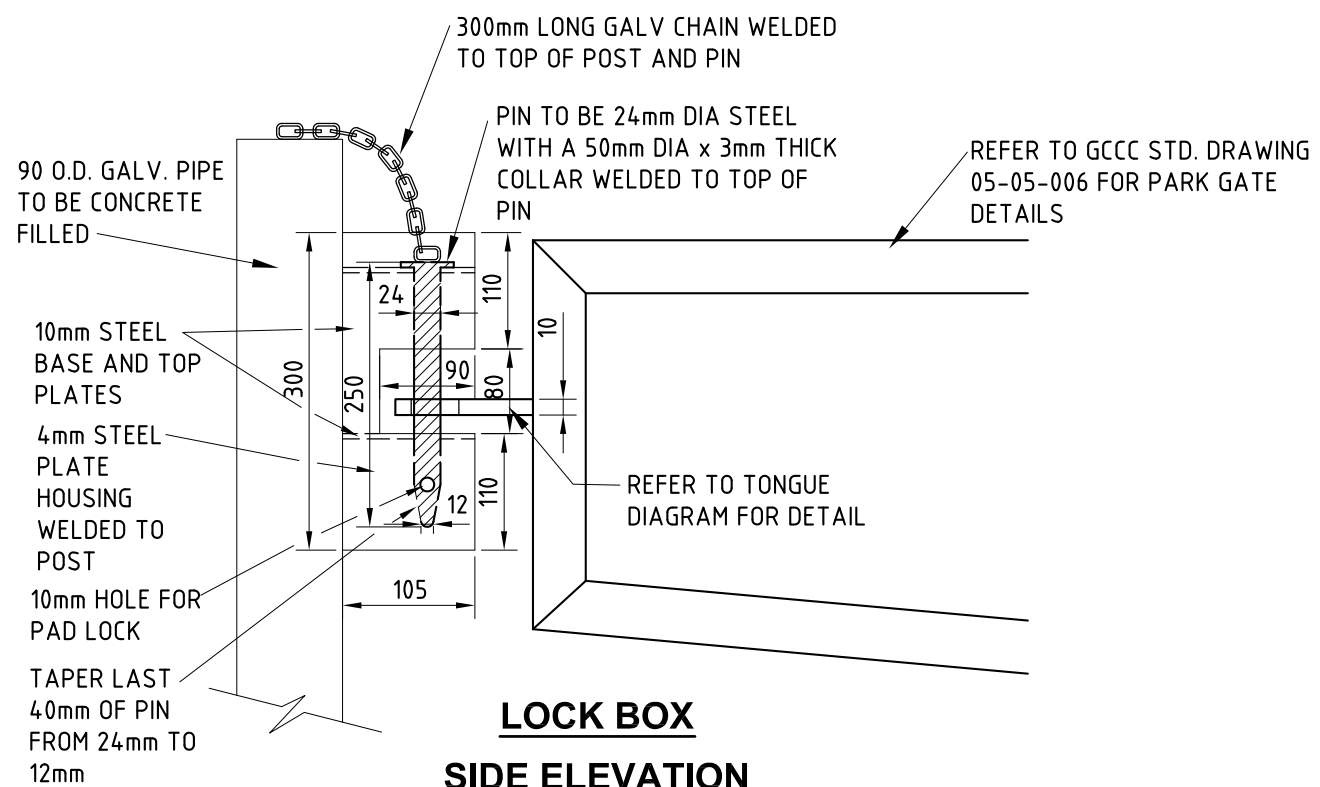

LOCK BOX SIDE ELEVATION

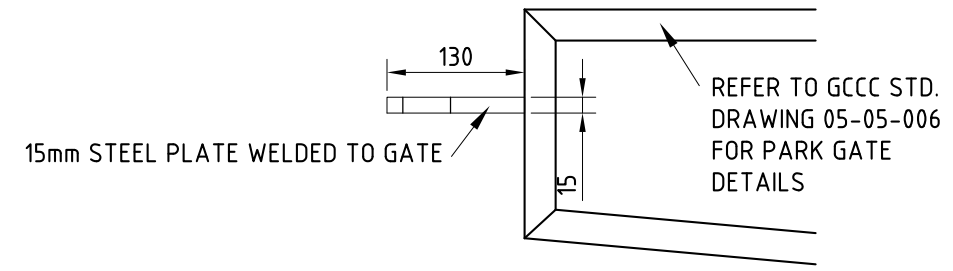

TONGUE SIDE ELEVATION

NOTES:

- WORKMANSHIP & MATERIALS TO BE IN ACCORDANCE WITH AS4100 & OTHER RELEVANT AUSTRALIAN STANDARDS.
- THE PIPE STEEL TO BE GRADE 350, ALL OTHER STEEL INCLUDING FLATS & PLATE TO BE AT LEAST GRADE 250.
- WELDING & PREPARATION TO BE IN ACCORDANCE WITH AS1554.1 CATEGORY SP GRADE E48XX & AS4100.
- ALL WELDING TO BE 6mm CONTINUOUS FILLET WELD.
- ALL WELDS TO BE WELL CLEANED & PAINTED IN ACCORDANCE WITH AS2312 CLAUSE 10.5.
- ALL POSTS TO BE SET VERTICALLY & ACCURATELY ALIGNED IN CONCRETE GRADE N25.
- ALL GALVANISING TO BE IN ACCORDANCE WITH AS/NZS 4680.
- DIMENSIONS ARE IN MILLIMETRES UNLESS STATED OTHERWISE.

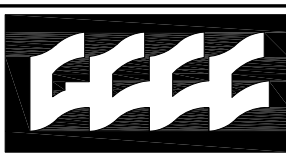

Gold Coast City Council
GOLD COAST CITY COUNCIL
PO BOX 5042
GOLD COAST MC 9729

THIS DRAWING IS NOT TO BE AMENDED WITHOUT REFERENCE TO STANDARDS COMMITTEE				CONTROLLED DOCUMENT	DO NOT SCALE TAKE FIGURED DIMENSIONS ONLY
No.	AMENDMENT	APPROVED	DATE	ISSUED	

DRAFTING BY TECHNICAL SERVICES BRANCH	
PASSED - COORDINATOR OPEN SPACE ASSETS	
SIGNED: CAMERON TAYLOR	DATE: 6/12/12
APPROVED - MANAGER PARKS & RECREATIONAL SERVICES	
SIGNED: RON JACOBS	DATE: 6/12/12

STANDARD DRAWING	
GATE LOCK BOX	

MICROFILMED
STANDARD DRAWING No. 13-05-609
ISSUE 2013 EDITION