

TOP VIEW

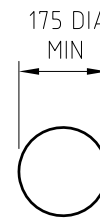

TOP VIEW

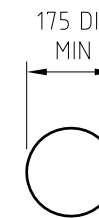

TOP VIEW

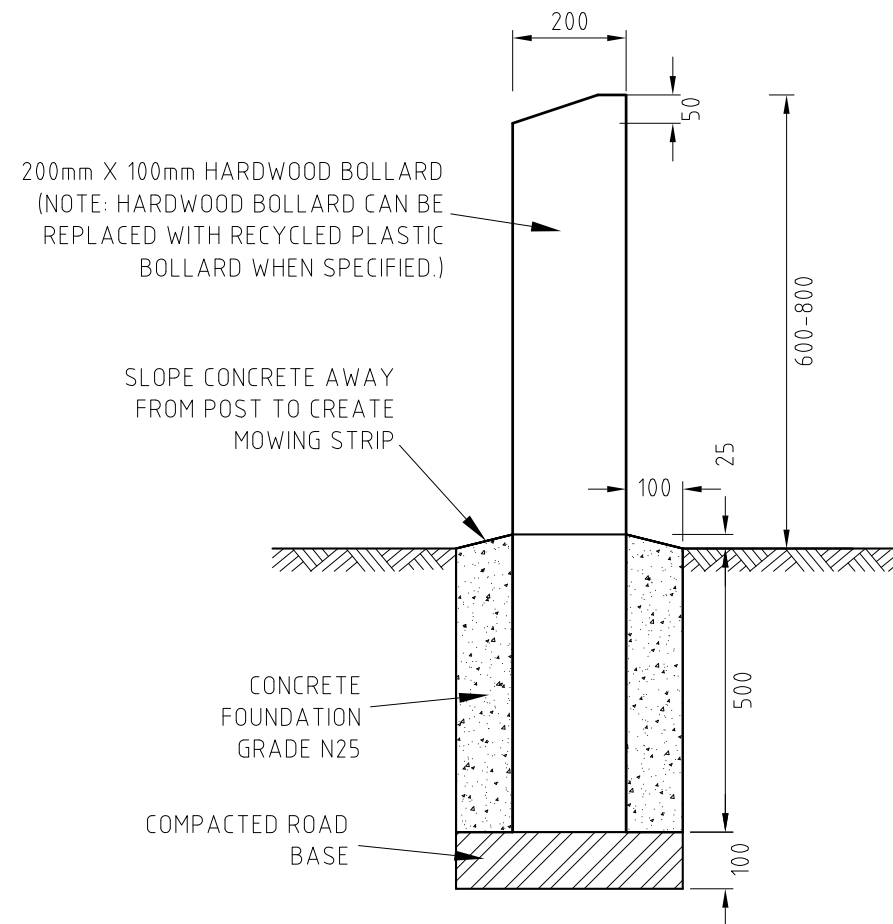

**BUSHLAND BOLLARD
TYPE 1**

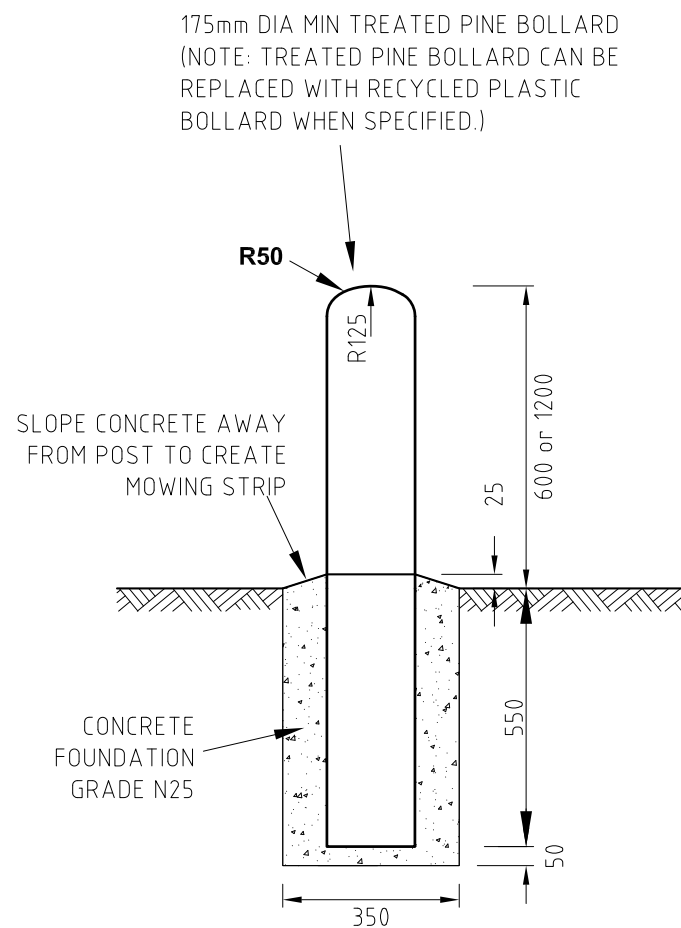

**PEDESTRIAN BOLLARD
TYPE 1**

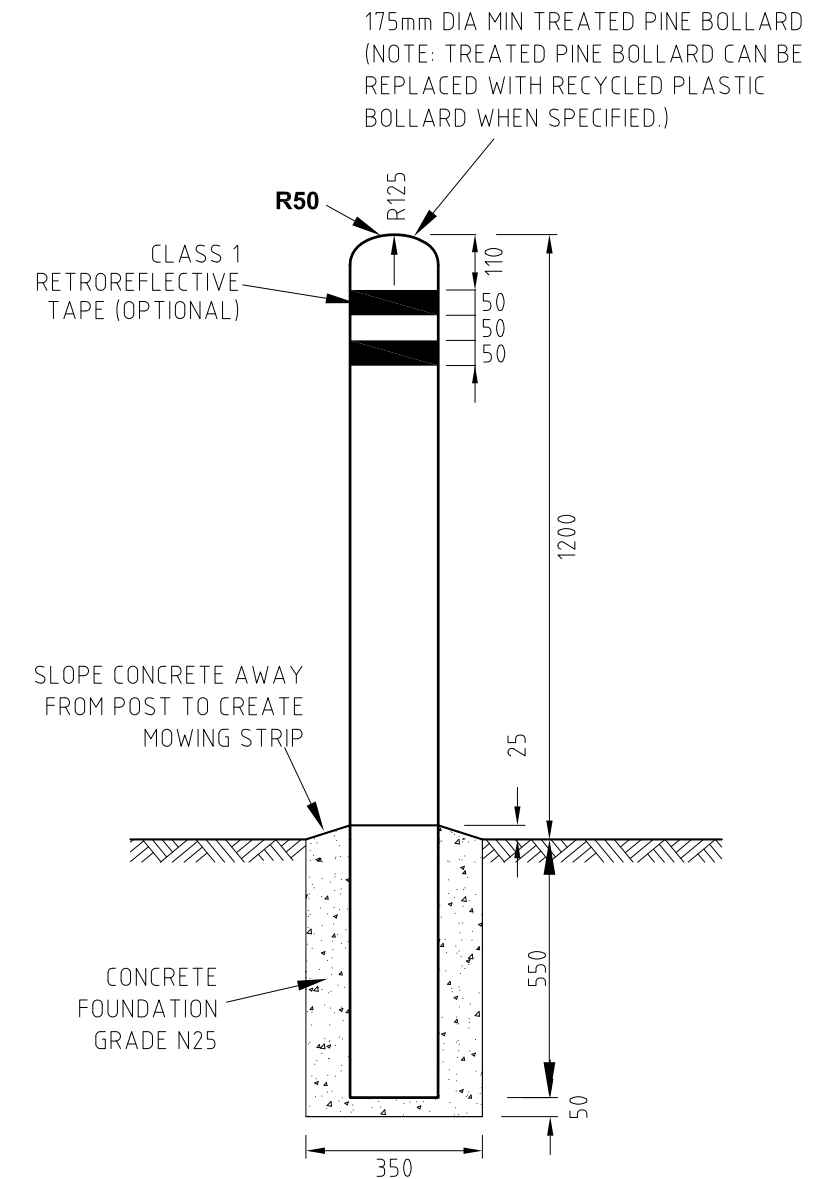

**PEDESTRIAN BOLLARD
TYPE 2**

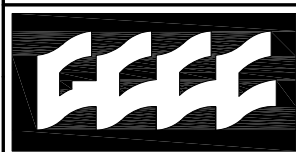

Gold Coast City Council

GOLD COAST CITY COUNCIL
PO BOX 5042
GOLD COAST MC 9729

THIS DRAWING IS NOT TO BE AMENDED WITHOUT
REFERENCE TO STANDARDS COMMITTEE

CONTROLLED
DOCUMENT

DO NOT SCALE
TAKE FIGURED DIMENSIONS ONLY

STANDARD DRAWING

MICROFILMED

No.	AMENDMENT	APPROVED	DATE	ISSUED

DRAFTING BY TECHNICAL SERVICES BRANCH	
PASSED - COORDINATOR OPEN SPACE ASSETS	
SIGNED:	
NAME: CAMERON TAYLOR	DATE: 6/12/12
APPROVED - MANAGER PARKS & RECREATIONAL SERVICES	
SIGNED:	
NAME: RON JACOBS	DATE: 6/12/12

BOLLARDS - TIMBER

STANDARD
DRAWING No.

13-05-616

ISSUE

2013 EDITION