

ASSEMBLY NOTES:

1. ALL FASTENERS TO BE INCLUDED IN SUPPLY OF ASSEMBLY UNLESS OTHERWISE INDICATED.
2. ALL SURFACES TO BE FREE FROM MARKS AND SCRATCHES.
3. USE A NICKEL BASED ANTI-SEIZURE LUBRICANT BETWEEN STAINLESS FIXINGS AND TAPPED STAINLESS STEEL UNLESS STATED.
4. PRE DRILL WOODEN SLATS PRIOR TO SCREWING TO AVOID SPLITTING

GENERAL NOTES:

1. ALL DIMENSIONS IN MILLIMETRES UNLESS OTHERWISE SHOWN.
2. TOLERANCES:
- LINEAR ARE $\pm 1.0\text{mm}$ UNLESS MARKED WITH $\times \pm 0.5\text{mm}$
- ANGULAR ARE $\pm 0.5^\circ$ UNLESS SPECIFIED OTHERWISE.
- HOLES AND RADII $\pm 0.5\text{mm}$ UNLESS SPECIFIED OTHERWISE.
3. NO DEVIATION FROM DRAWING WILL BE ACCEPTED WITHOUT PRIOR WRITTEN APPROVAL.
4. DO NOT SCALE FROM DRAWINGS. USE DIMENSIONS PROVIDED IF THIS IS INSUFFICIENT OR AMBIGUOUS CONTACT GOLD COAST CITY COUNCIL FOR CLARIFICATION.

HOT DIP GALVANISED STEEL FABRICATION NOTES:

1. ALL SPLATTER AND SLAG TO BE REMOVED.
2. ALL EDGES TO BE DEBURRED AND FREE OF SHARP EDGES AND PROTRUSIONS.
3. WELDING AND PREPARATION TO BE IN ACCORDANCE WITH AS1554.1 CATEGORY SP GRADE E48XX AND AS4100.
4. ALL WELDS TO BE 6mm CONTINUOUS FILLET WELD.
5. ALL GALVANISED HOLLOW SECTIONS TO HAVE ADEQUATE, IDEALLY HIDDEN VENTILATION HOLES.
6. ALL HOLES TO BE RE-DRILLED AFTER GALVANISING.
7. ALL TAPPED HOLES TO BE RE-TAPPED AFTER GALVANISING.
8. ALL STANDARD SECTIONS TO BE DOCKED AT 90° UNLESS STATED OTHERWISE.
9. GALVANISE IN ACCORDANCE WITH AS/NZS 4680. MINIMUM THICKNESS MUST BE NOT LESS THAN 500 g/m².
10. CERTIFICATES OF CONFORMITY MUST ACCOMPANY ANY MATERIALS USED IN THE FABRICATION PROCESS.

NOTE:-
THIS DRAWING HAS BEEN SOURCED FROM HUBB STREET EQUIPMENT. THIS DRAWING IS NOT DRAWN TO GCCC STANDARD T.P.R GUIDELINES.

PARTS LIST				
NO.	TITLE	MATERIAL	DRAWING #	QTY.
1	Frame	Mild Steel Hot Dipped Galvanized	-	1
2	Urban Slat	Spotted Gum	05-530	18
3	14 gauge x 32mm Csk Hex Pin Security Woodscrew	304 S/S	-	54
4	M12 x 250 HILTI HAS System	Galvanized Steel	-	4

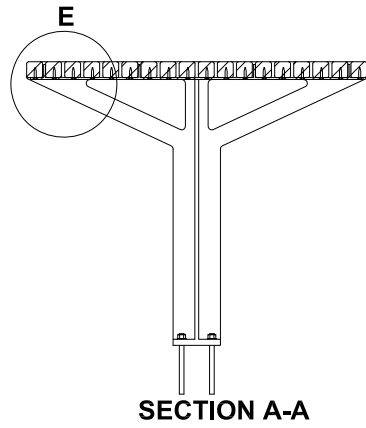
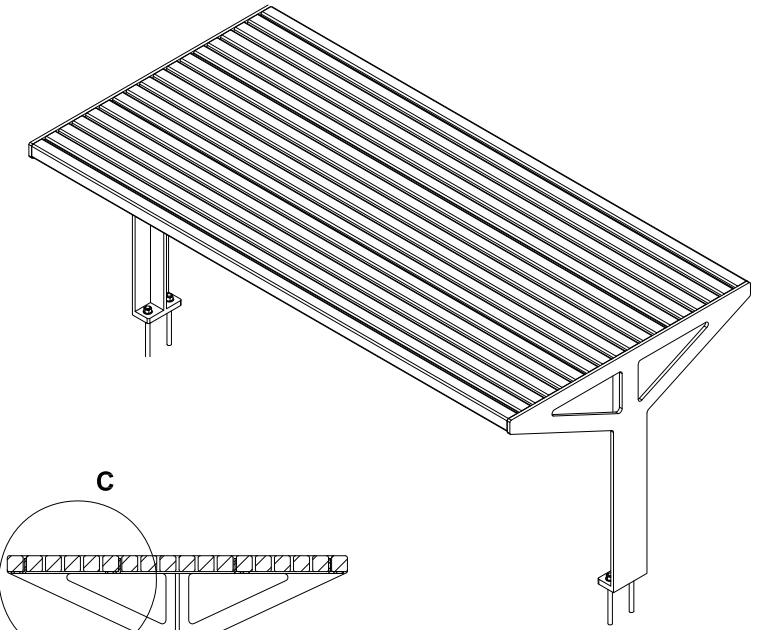

SECTION A-A

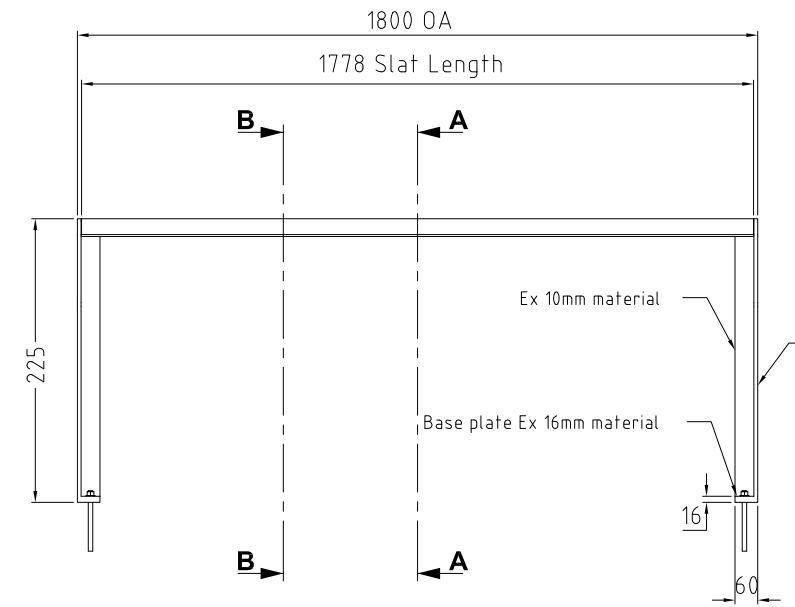

FRONT VIEW

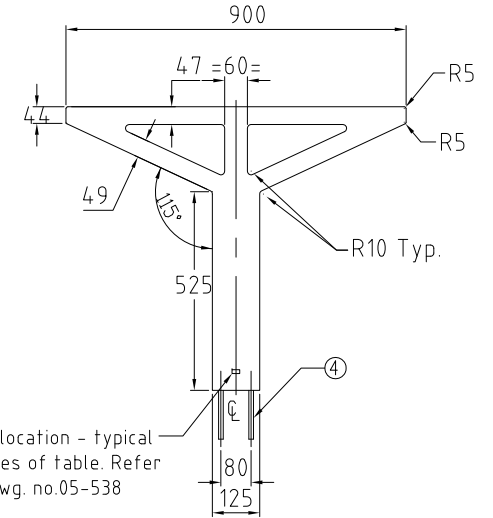

RIGHT VIEW

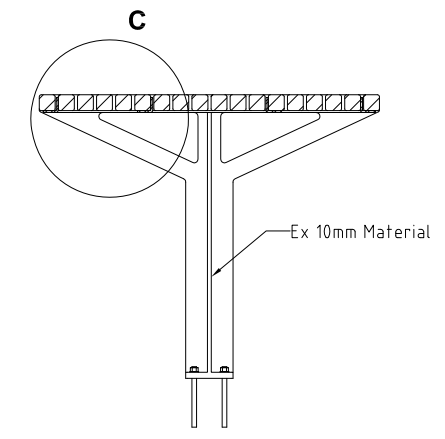

SECTION B-B

NOTE: SLAT ATTACHMENT Use a jig or spacers to allow correct and even spacing of the slats. Position slats and pilot ($\phi 3.5\text{mm}$) hole before securing with fasteners. Always predrill Timber Slats before fastening. Mount slats centre down.

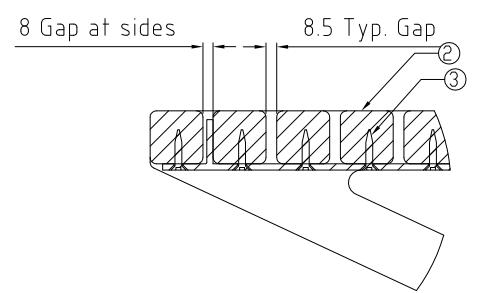

DETAIL E

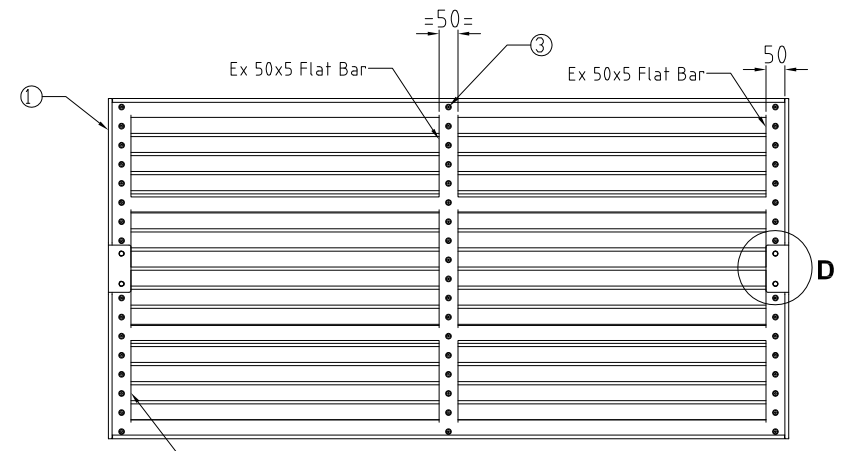

BOTTOM VIEW

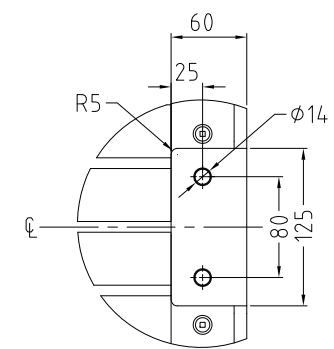

DETAIL D

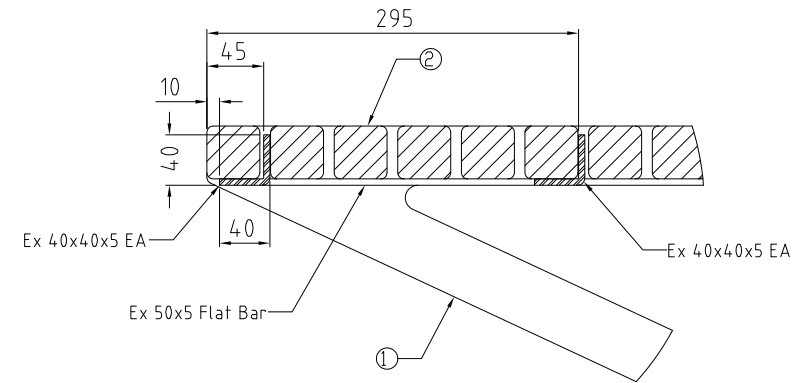

DETAIL C



THIS DRAWING IS NOT TO BE AMENDED WITHOUT REFERENCE TO STANDARDS COMMITTEE				CONTROLLED DOCUMENT	DO NOT SCALE TAKE FIGURED DIMENSIONS ONLY	STANDARD DRAWING	MICROFILMED
No.	AMENDMENT	APPROVED	DATE	ISSUED	TECHNICAL SERVICES BRANCH		STANDARD DRAWING No. 13-05-503

DRAFTING BY		TECHNICAL SERVICES BRANCH	
PASSED - COORDINATOR OPEN SPACE ASSETS			
SIGNED:	CAMERON TAYLOR	DATE:	6/12/12
APPROVED - MANAGER PARKS & RECREATIONAL SERVICES			
SIGNED:	RON JACOBS	DATE:	6/12/12

URBAN SUITE - PICNIC TABLE		THIS DRAWING HAS BEEN SOURCED FROM HUBB STREET EQUIPMENT DRAWING NUMBERS 7432.901 TO 7432.938
ISSUE 2013 EDITION		