

ASSEMBLY NOTES:

1. ALL FASTENERS TO BE INCLUDED IN SUPPLY OF ASSEMBLY UNLESS OTHERWISE INDICATED.
2. ALL SURFACES TO BE FREE FROM MARKS AND SCRATCHES. USE A NICKEL BASED ANTI-SEIZURE LUBRICANT BETWEEN STAINLESS FIXINGS AND TAPPED STAINLESS STEEL UNLESS STATED.
4. PRE DRILL WOODEN SLATS PRIOR TO SCREWING TO AVOID SPLITTING

GENERAL NOTES:

1. ALL DIMENSIONS IN MILLIMETRES UNLESS OTHERWISE SHOWN.
2. TOLERANCES:
- LINEAR ARE $\pm 1.0\text{mm}$ UNLESS MARKED WITH $\times \pm 0.5\text{mm}$
- ANGULAR ARE $\pm 0.5^\circ$ UNLESS SPECIFIED OTHERWISE.
- HOLES AND RADII $\pm 0.5\text{mm}$ UNLESS SPECIFIED OTHERWISE.
3. NO DEVIATION FROM DRAWING WILL BE ACCEPTED WITHOUT PRIOR WRITTEN APPROVAL.
4. DO NOT SCALE FROM DRAWINGS. USE DIMENSIONS PROVIDED IF THIS IS INSUFFICIENT OR AMBIGUOUS CONTACT GOLD COAST CITY COUNCIL FOR CLARIFICATION.

HOT DIP GALVANISED STEEL FABRICATION NOTES:

1. ALL SPLATTER AND SLAG TO BE REMOVED.
2. ALL EDGES TO BE DEBURRED AND FREE OF SHARP EDGES AND PROTRUSIONS.
3. WELDING AND PREPARATION TO BE IN ACCORDANCE WITH AS1554.1 CATEGORY SP GRADE E48XX AND AS4100.
4. ALL WELDS TO BE 6mm CONTINUOUS FILLET WELD.
5. ALL GALVANISED HOLLOW SECTIONS TO HAVE ADEQUATE, IDEALLY HIDDEN VENTILATION HOLES.
6. ALL HOLES TO BE RE-DRILLED AFTER GALVANISING.
7. ALL TAPPED HOLES TO BE RE-TAPPED AFTER GALVANISING.
8. ALL STANDARD SECTIONS TO BE DOCKED AT 90° UNLESS STATED OTHERWISE.
9. GALVANISE IN ACCORDANCE WITH AS/NZS 4680. MINIMUM THICKNESS MUST BE NOT LESS THAN 500 g/m².
10. CERTIFICATES OF CONFORMITY MUST ACCOMPANY ANY MATERIALS USED IN THE FABRICATION PROCESS.

NOTE:-
THIS DRAWING HAS BEEN SOURCED FROM HUBB STREET EQUIPMENT. THIS DRAWING IS NOT DRAWN TO GCCC STANDARD T.P.R GUIDELINES.

PARTS LIST			
NO.	TITLE	DRAWING NUMBER	QTY.
1	Urban Table	05-503	1
2	Urban Bench	05-502	2

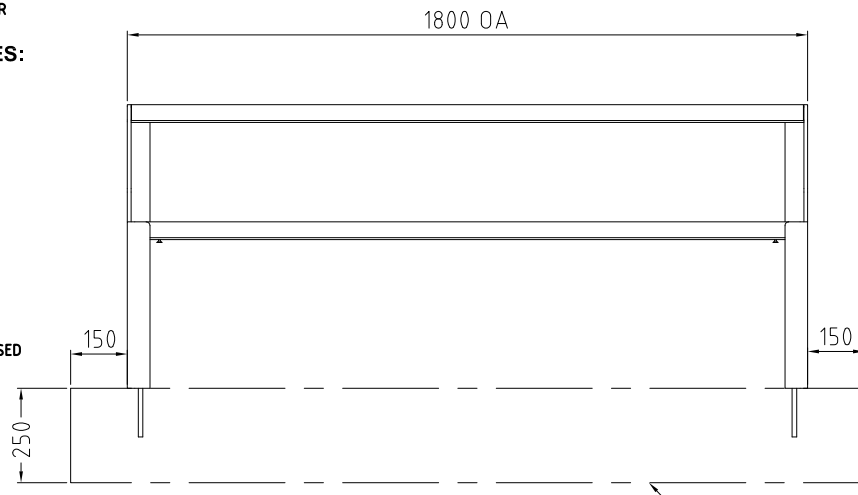

FRONT VIEW

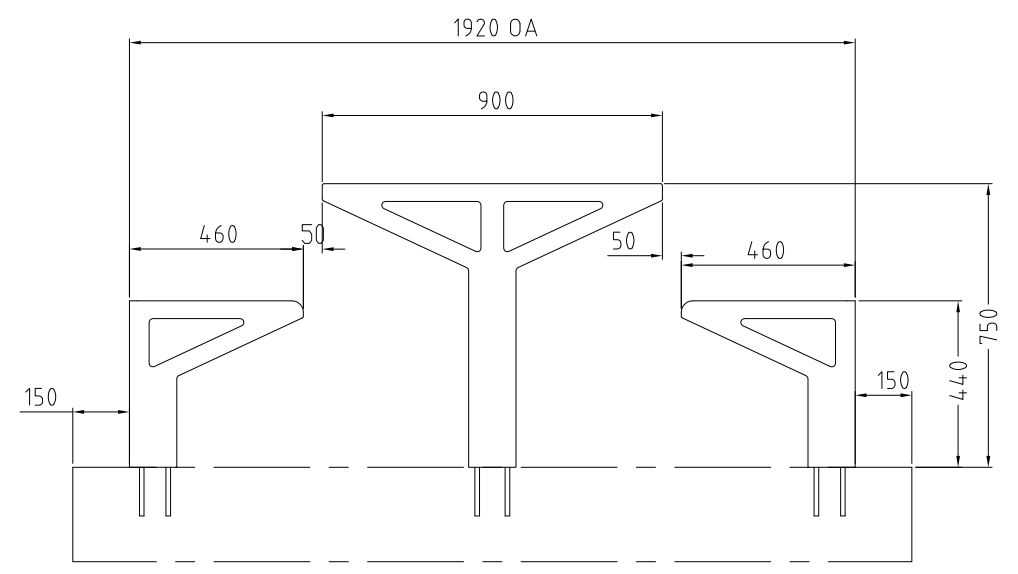

SIDE VIEW

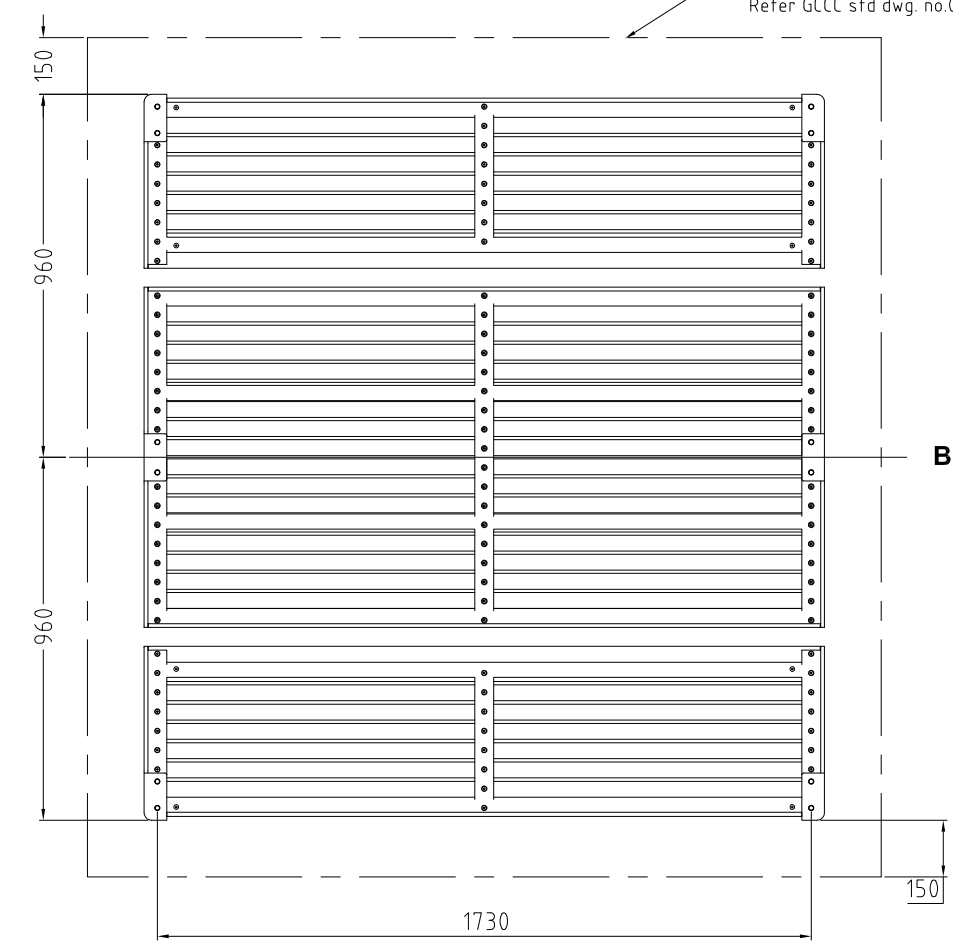

BOTTOM VIEW

Dashed line represents concrete pad.
Refer GCCC std dwg. no.05-539

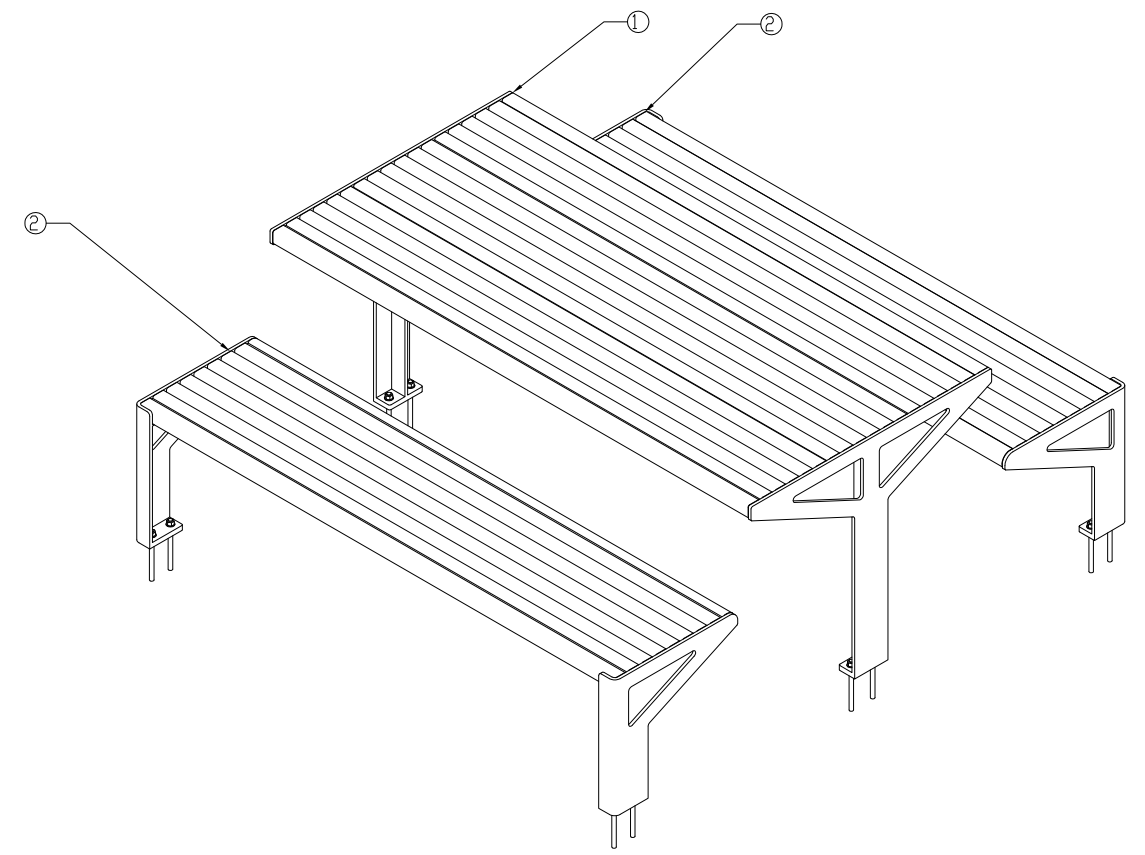

Gold Coast City Council
GOLD COAST CITY COUNCIL
PO BOX 5042
GOLD COAST MC 9729

THIS DRAWING IS NOT TO BE AMENDED WITHOUT REFERENCE TO STANDARDS COMMITTEE

No.	AMENDMENT	APPROVED	DATE	ISSUED

CONTROLLED DOCUMENT

DO NOT SCALE
TAKE FIGURED DIMENSIONS ONLY

DRAFTING BY
TECHNICAL SERVICES BRANCH

PASSED - COORDINATOR OPEN SPACE ASSETS
SIGNED: _____
NAME: CAMERON TAYLOR DATE: 6/12/12

APPROVED - MANAGER PARKS & RECREATIONAL SERVICES
SIGNED: _____
NAME: RON JACOBS DATE: 6/12/12

STANDARD DRAWING

URBAN SUITE - PICNIC SETTING

THIS DRAWING HAS BEEN SOURCED FROM HUBB STREET EQUIPMENT DRAWING NUMBERS 7432.901 TO 7432.938

MICROFILMED

STANDARD DRAWING No.
13-05-506

ISSUE
2013 EDITION