

PARTS LIST			
NO.	TITLE	DRAWING #	QTY.
1	Natural Bench	05-512	1
2	Natural Extended Picnic Table	05-515	1
3	Natural Extended Bench	05-514	1

**ASSEMBLY NOTES:**

1. ALL FASTENERS TO BE INCLUDED IN SUPPLY OF ASSEMBLY UNLESS OTHERWISE INDICATED.
2. ALL SURFACES TO BE FREE FROM MARKS AND SCRATCHES.
3. USE A NICKEL BASED ANTI-SEIZURE LUBRICANT BETWEEN STAINLESS FIXINGS AND TAPPED STAINLESS STEEL UNLESS STATED.
4. PRE DRILL WOODEN SLATS PRIOR TO SCREWING TO AVOID SPLITTING

**GENERAL NOTES:**

1. ALL DIMENSIONS IN MILLIMETRES UNLESS OTHERWISE SHOWN.
2. TOLERANCES:  
- LINEAR ARE  $\pm 1.0\text{mm}$  UNLESS MARKED WITH  $\times \pm 0.5\text{mm}$   
- ANGULAR ARE  $\pm 0.5^\circ$  UNLESS SPECIFIED OTHERWISE.  
- HOLES AND RADII  $\pm 0.5\text{mm}$  UNLESS SPECIFIED OTHERWISE.
3. NO DEVIATION FROM DRAWING WILL BE ACCEPTED WITHOUT PRIOR WRITTEN APPROVAL.
4. DO NOT SCALE FROM DRAWINGS. USE DIMENSIONS PROVIDED IF THIS IS INSUFFICIENT OR AMBIGUOUS CONTACT GOLD COAST CITY COUNCIL FOR CLARIFICATION.

**HOT DIP GALVANISED STEEL FABRICATION NOTES:**

1. ALL SPLATTER AND SLAG TO BE REMOVED.
2. ALL EDGES TO BE DEBURRED AND FREE OF SHARP EDGES AND PROTRUSIONS.
3. WELDING AND PREPARATION TO BE IN ACCORDANCE WITH AS1554.1 CATEGORY SP GRADE E48XX AND AS4100.
4. ALL WELDS TO BE 6mm CONTINUOUS FILLET WELD.
5. ALL GALVANISED HOLLOW SECTIONS TO HAVE ADEQUATE, IDEALLY HIDDEN VENTILATION HOLES.
6. ALL HOLES TO BE RE-DRILLED AFTER GALVANISING.
7. ALL TAPPED HOLES TO BE RE-TAPPED AFTER GALVANISING.
8. ALL STANDARD SECTIONS TO BE DOCKED AT 90° UNLESS STATED OTHERWISE.
9. GALVANISE IN ACCORDANCE WITH AS/NZS 4680. MINIMUM THICKNESS MUST BE NOT LESS THAN 500 g/m<sup>2</sup>.
10. CERTIFICATES OF CONFORMITY MUST ACCOMPANY ANY MATERIALS USED IN THE FABRICATION PROCESS.

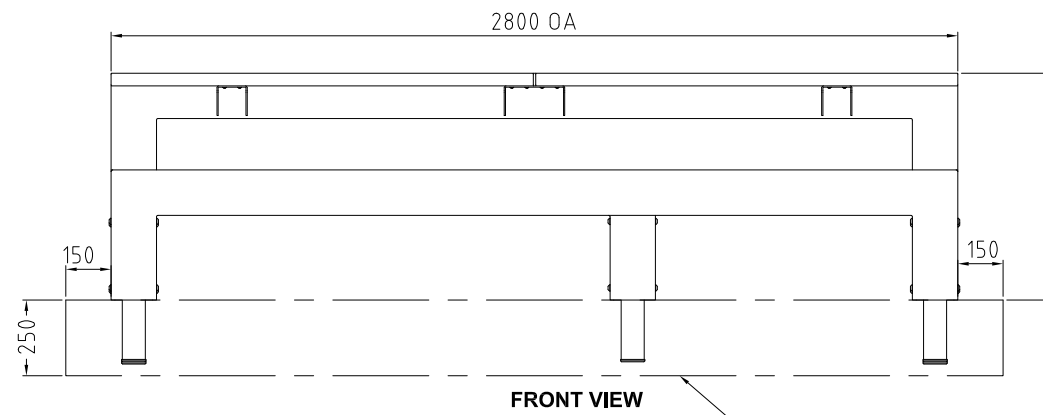

FRONT VIEW

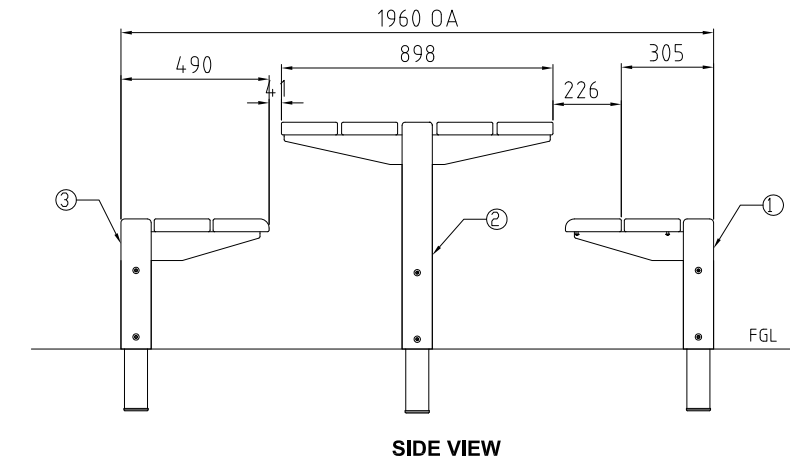

SIDE VIEW

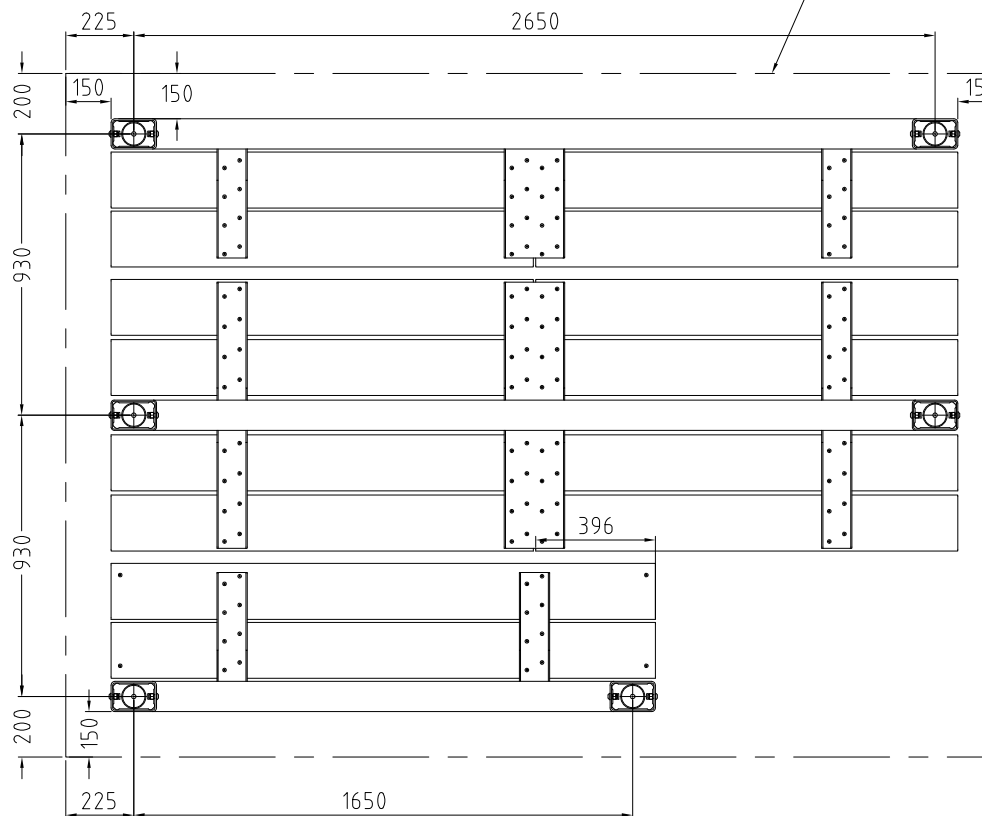

BOTTOM VIEW

Dashed line represents concrete slab.  
Refer to GCCC dwg. no. 05-539

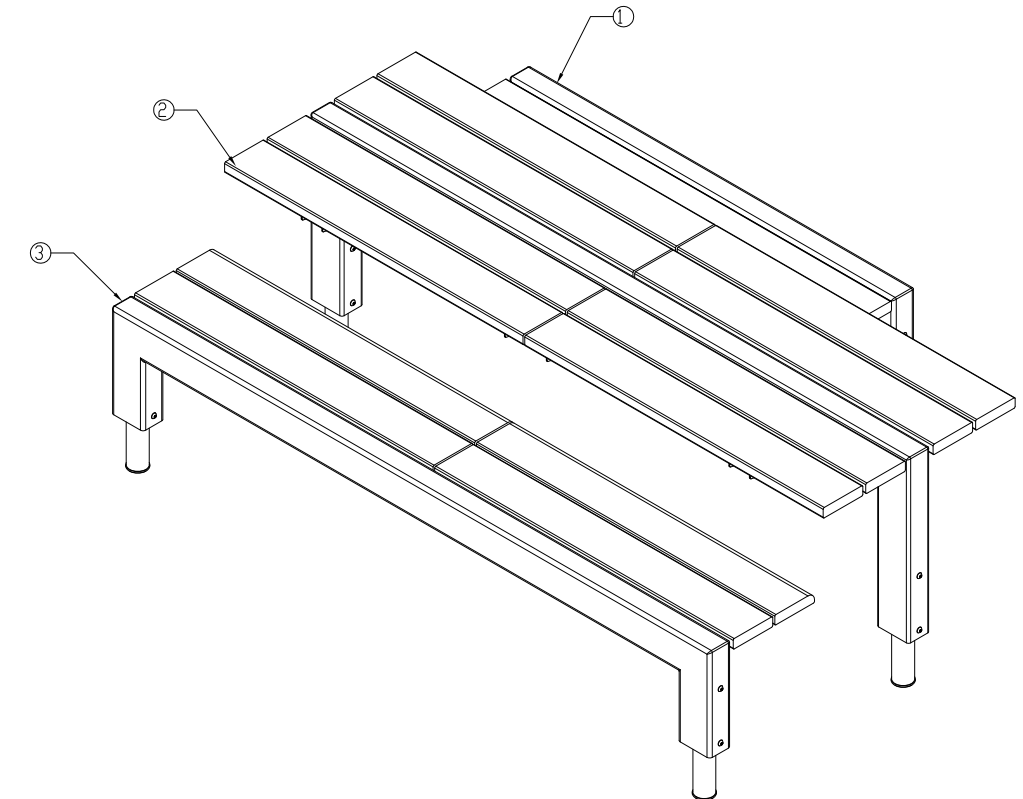

NOTE:-  
THIS DRAWING HAS BEEN SOURCED FROM HUBB STREET EQUIPMENT. THIS DRAWING IS NOT DRAWN TO GCCC STANDARD T.P.R GUIDELINES.



**Gold Coast City Council**

GOLD COAST CITY COUNCIL  
PO BOX 5042  
GOLD COAST MC 9729

THIS DRAWING IS NOT TO BE AMENDED WITHOUT REFERENCE TO STANDARDS COMMITTEE

CONTROLLED DOCUMENT

DO NOT SCALE TAKE FIGURED DIMENSIONS ONLY

**STANDARD DRAWING**

MICROFILMED

DRAFTING BY  
**TECHNICAL SERVICES BRANCH**

PASSED - COORDINATOR OPEN SPACE ASSETS  
SIGNED: CAMERON TAYLOR DATE: 6/12/12

APPROVED - MANAGER PARKS & RECREATIONAL SERVICES  
SIGNED: RON JACOBS DATE: 6/12/12

**NATURAL SUITE - EXTENDED PICNIC SETTING**

STANDARD DRAWING No.

**13-05-517**

ISSUE

**2013 EDITION**

THIS DRAWING HAS BEEN SOURCED FROM HUBB STREET EQUIPMENT DRAWING NUMBERS 7432.901 TO 7432.938

No.	AMENDMENT	APPROVED	DATE	ISSUED