

GENERAL NOTES:

1. ALL DIMENSIONS IN MILLIMETRES UNLESS OTHERWISE SHOWN.
2. TOLERANCES:
 - LINEAR ARE $\pm 1.0\text{mm}$ UNLESS MARKED WITH $\times \pm 0.5\text{mm}$
 - ANGULAR ARE $\pm 0.5^\circ$ UNLESS SPECIFIED OTHERWISE.
 - HOLES AND RADII $\pm 0.5\text{mm}$ UNLESS SPECIFIED OTHERWISE.
3. NO DEVIATION FROM DRAWING WILL BE ACCEPTED WITHOUT PRIOR WRITTEN APPROVAL.
4. DO NOT SCALE FROM DRAWINGS. USE DIMENSIONS PROVIDED IF THIS IS INSUFFICIENT OR AMBIGUOUS CONTACT GOLD COAST CITY COUNCIL FOR CLARIFICATION.

PARTS LIST			
NO.	TITLE	DRAWING #	QTY.
1	Waterside Picnic Table	05-222	1
2	Waterside Bench	05-221	2

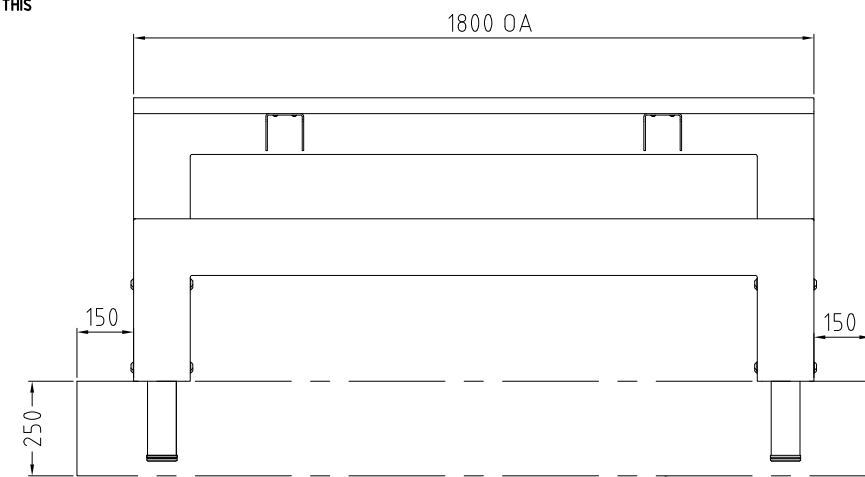

FRONT VIEW

Dashed line represents concrete pad. Refer GCCC std dwg. no.05-539

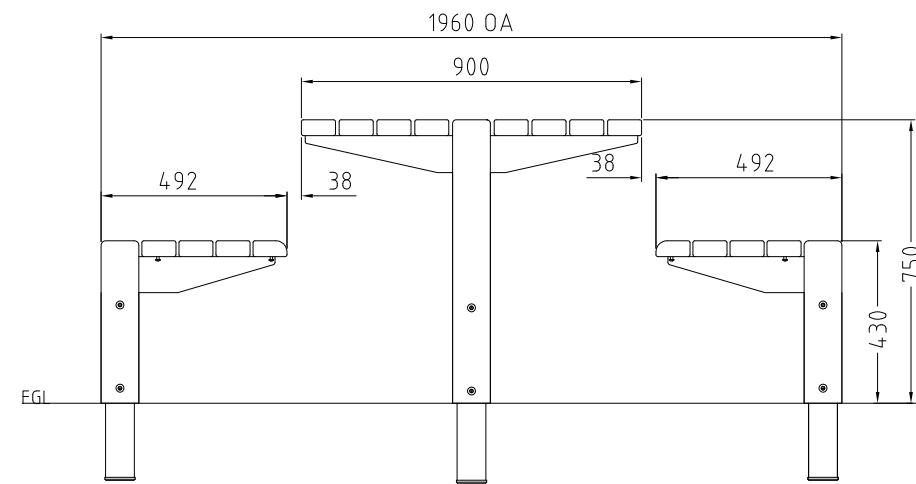

RIGHT VIEW

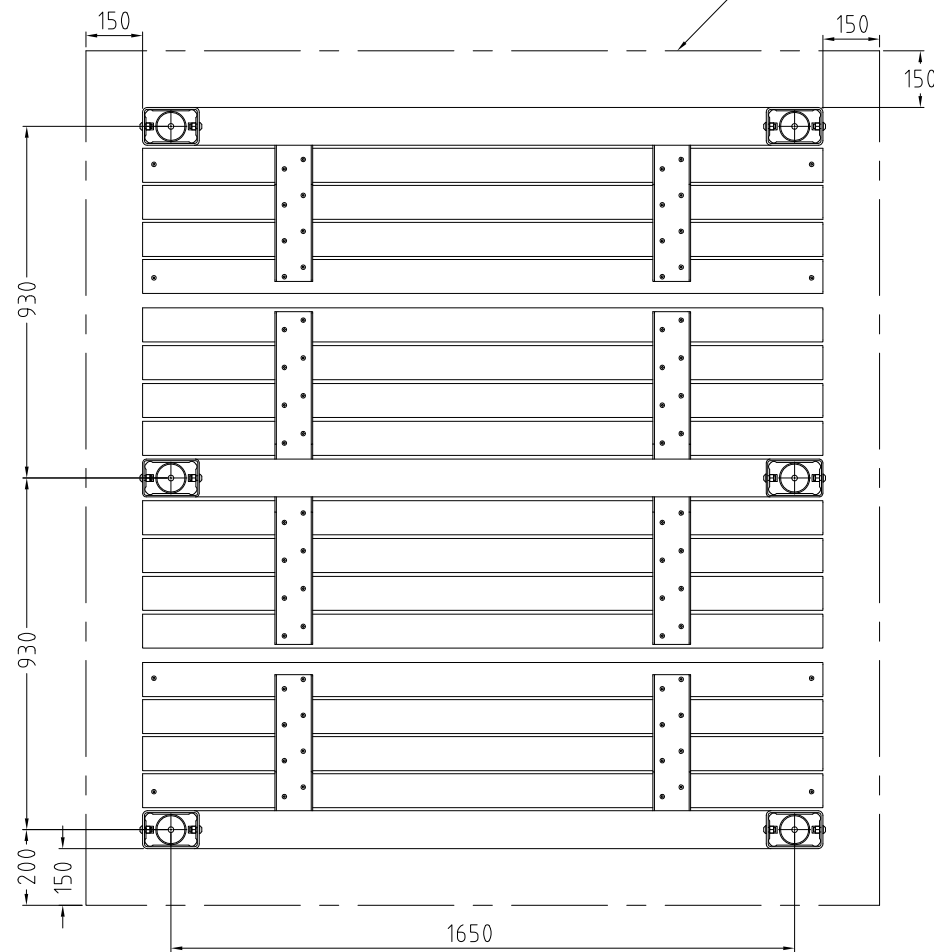

BOTTOM VIEW

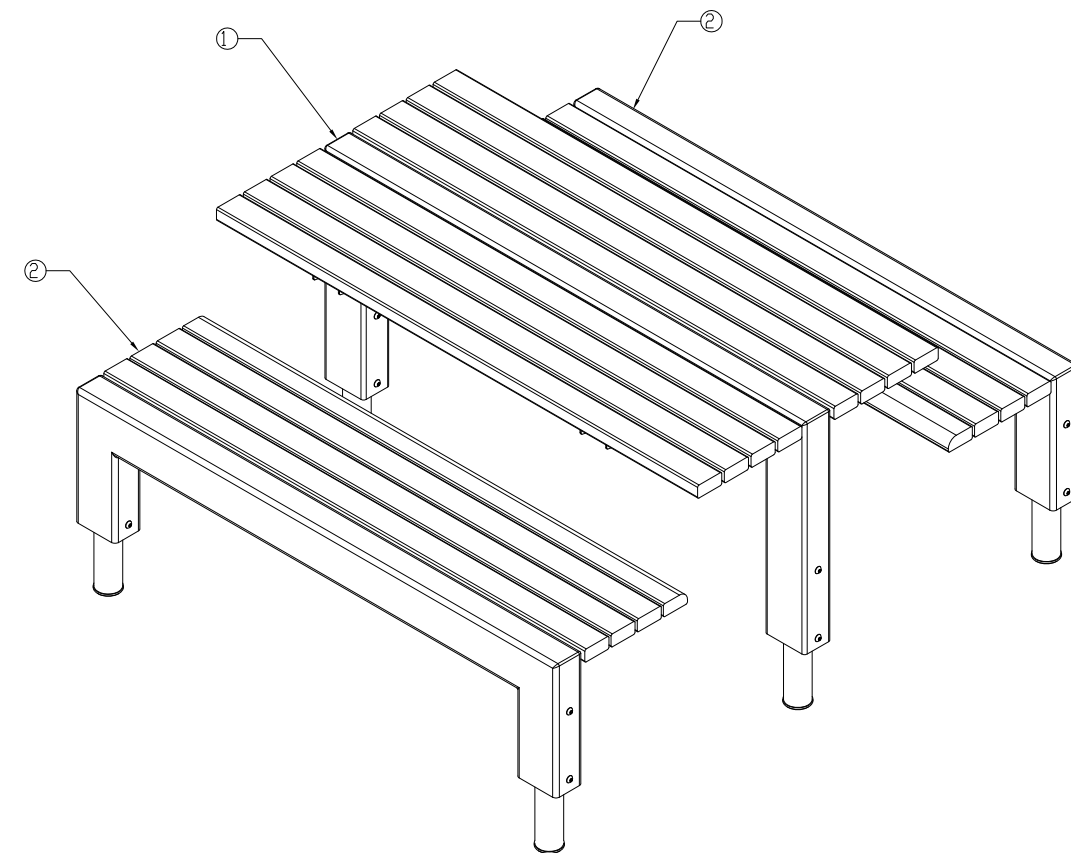

NOTE:-
 THIS DRAWING HAS BEEN SOURCED FROM HUBB STREET EQUIPMENT. THIS DRAWING IS NOT DRAWN TO GCCC STANDARD T.P.R GUIDELINES.



Gold Coast City Council

GOLD COAST CITY COUNCIL
 PO BOX 5042
 GOLD COAST MC 9729

THIS DRAWING IS NOT TO BE AMENDED WITHOUT REFERENCE TO STANDARDS COMMITTEE

CONTROLLED DOCUMENT

DO NOT SCALE TAKE FIGURED DIMENSIONS ONLY

STANDARD DRAWING

MICROFILMED

DRAFTING BY
TECHNICAL SERVICES BRANCH

PASSED - COORDINATOR OPEN SPACE ASSETS
 SIGNED: CAMERON TAYLOR DATE: 6/12/12

APPROVED - MANAGER PARKS & RECREATIONAL SERVICES
 SIGNED: RON JACOBS DATE: 6/12/12

WATERSIDE SUITE - PICNIC SETTING

THIS DRAWING HAS BEEN SOURCED FROM HUBB STREET EQUIPMENT DRAWING NUMBERS 7432.901 TO 7432.938

STANDARD DRAWING No.

13-05-525

ISSUE

2013 EDITION

No.	AMENDMENT	APPROVED	DATE	ISSUED