

**GENERAL NOTES:**

1. ALL DIMENSIONS IN MILLIMETRES UNLESS OTHERWISE SHOWN.
2. TOLERANCES:
  - LINEAR ARE  $\pm 1.0\text{mm}$  UNLESS MARKED WITH  $\times \pm 0.5\text{mm}$
  - ANGULAR ARE  $\pm 0.5^\circ$  UNLESS SPECIFIED OTHERWISE.
  - HOLES AND RADII  $\pm 0.5\text{mm}$  UNLESS SPECIFIED OTHERWISE.
3. NO DEVIATION FROM DRAWING WILL BE ACCEPTED WITHOUT PRIOR WRITTEN APPROVAL.
4. DO NOT SCALE FROM DRAWINGS. USE DIMENSIONS PROVIDED IF THIS IS INSUFFICIENT OR AMBIGUOUS CONTACT GOLD COAST CITY COUNCIL FOR CLARIFICATION.

| PARTS LIST |                                 |           |      |
|------------|---------------------------------|-----------|------|
| NO.        | TITLE                           | DRAWING # | QTY. |
| 1          | Waterside Extended Picnic Table | 05-224    | 1    |
| 2          | Waterside Extended Bench        | 05-223    | 1    |
| 3          | Waterside Bench                 | 05-221    | 1    |

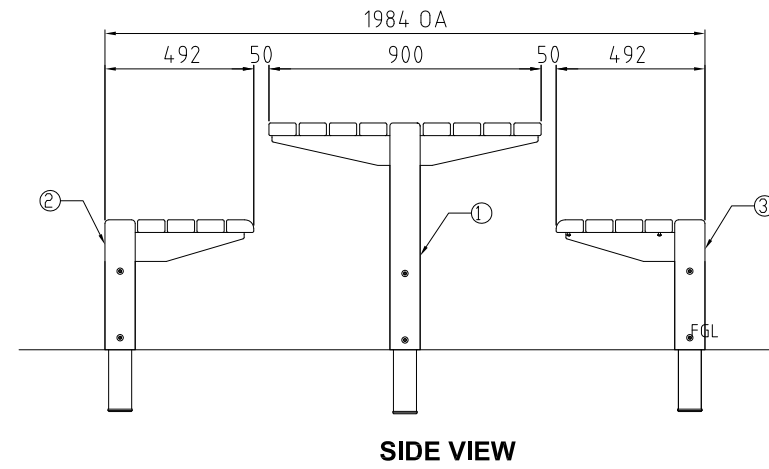
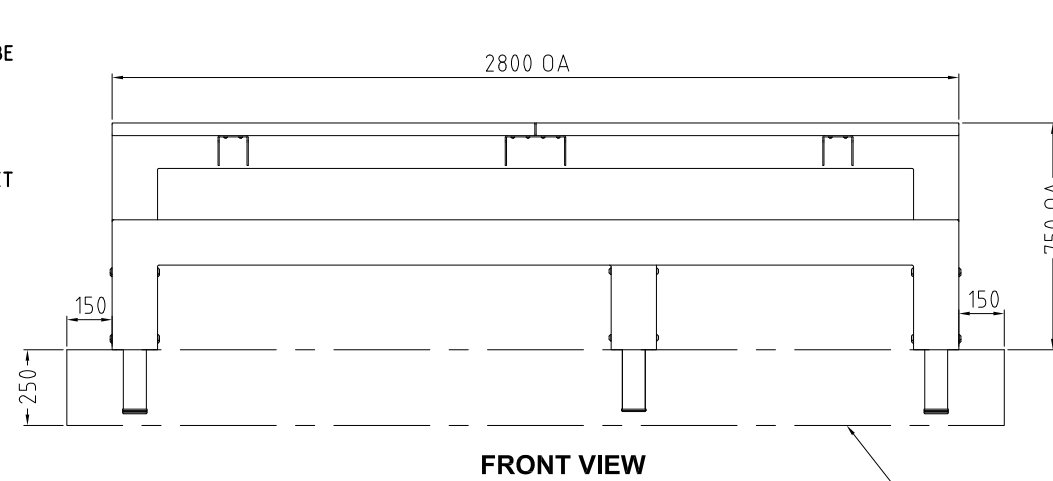

Dashed line represents concrete slab.  
Refer GCCC sts dwg no. 05-539.

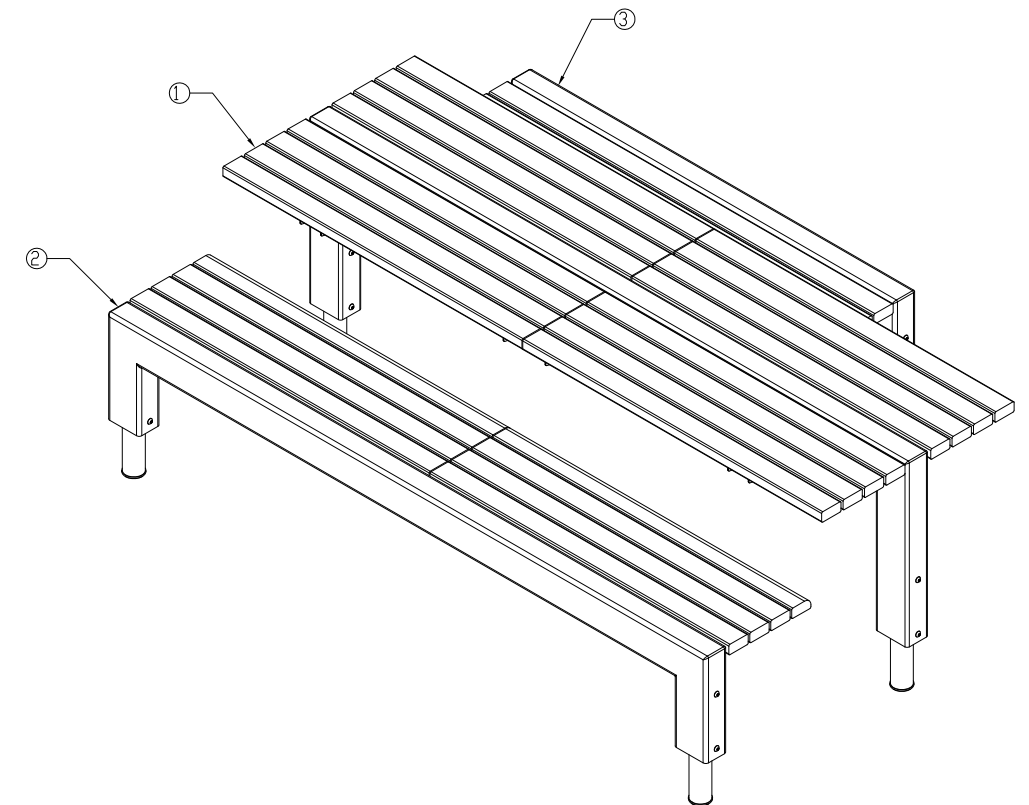
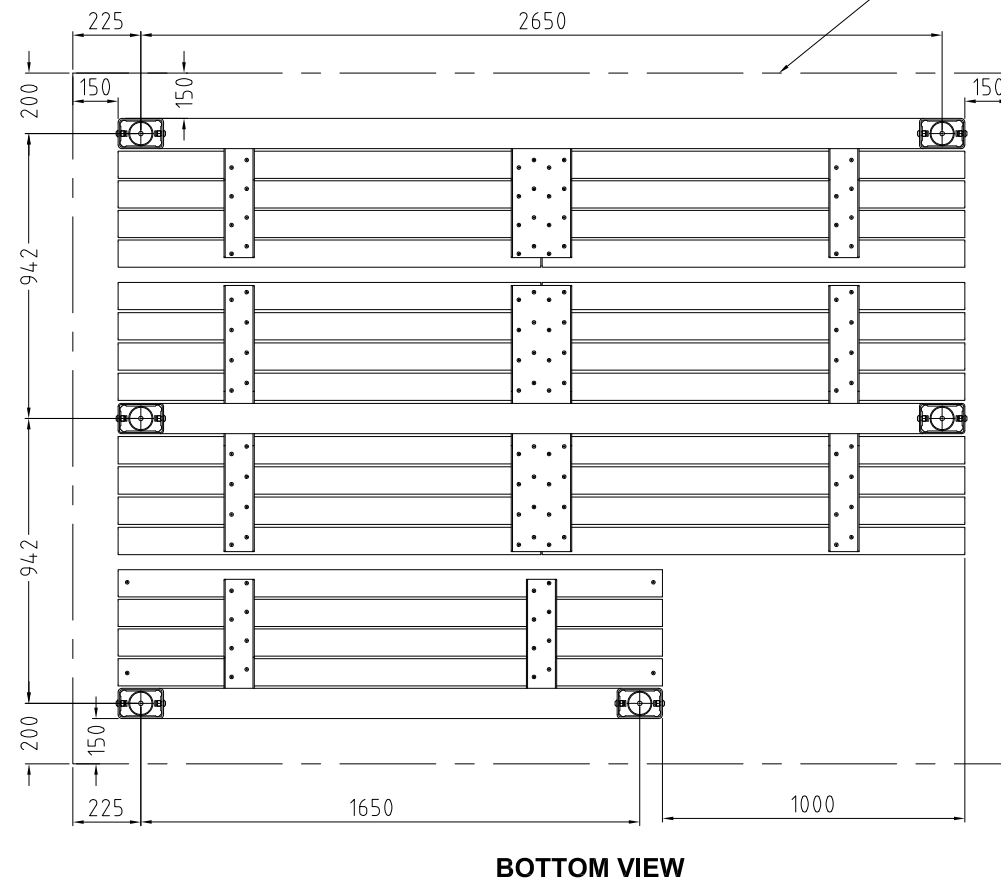

**NOTE:-**  
THIS DRAWING HAS BEEN SOURCED FROM HUBB STREET EQUIPMENT. THIS DRAWING IS NOT DRAWN TO GCCC STANDARD T.P.R GUIDELINES.



**Gold Coast City Council**

GOLD COAST CITY COUNCIL  
PO BOX 5042  
GOLD COAST MC 9729

THIS DRAWING IS NOT TO BE AMENDED WITHOUT REFERENCE TO STANDARDS COMMITTEE

CONTROLLED DOCUMENT

DO NOT SCALE  
TAKE FIGURED DIMENSIONS ONLY

**STANDARD DRAWING**

MICROFILMED

DRAFTING BY  
**TECHNICAL SERVICES BRANCH**

PASSED - COORDINATOR OPEN SPACE ASSETS  
SIGNED: CAMERON TAYLOR DATE: 6/12/12

APPROVED - MANAGER PARKS & RECREATIONAL SERVICES  
SIGNED: RON JACOBS DATE: 6/12/12

**WATERSIDE SUITE - EXTENDED PICNIC SETTING**

STANDARD DRAWING No.

**13-05-526**

ISSUE

**2013 EDITION**

THIS DRAWING HAS BEEN SOURCED FROM HUBB STREET EQUIPMENT DRAWING NUMBERS 7432.901 TO 7432.938

| No. | AMENDMENT | APPROVED | DATE | ISSUED |
|-----|-----------|----------|------|--------|
|     |           |          |      |        |