

GENERAL NOTES:

1. ALL DIMENSIONS IN MILLIMETRES UNLESS OTHERWISE SHOWN.
2. TOLERANCES:
 - LINEAR ARE $\pm 1.0\text{mm}$ UNLESS MARKED WITH $\times \pm 0.5\text{mm}$
 - ANGULAR ARE $\pm 0.5^\circ$ UNLESS SPECIFIED OTHERWISE.
 - HOLES AND RADII $\pm 0.5\text{mm}$ UNLESS SPECIFIED OTHERWISE.
3. NO DEVIATION FROM DRAWING WILL BE ACCEPTED WITHOUT PRIOR WRITTEN APPROVAL.
4. DO NOT SCALE FROM DRAWINGS. USE DIMENSIONS PROVIDED IF THIS IS INSUFFICIENT OR AMBIGUOUS CONTACT GOLD COAST CITY COUNCIL FOR CLARIFICATION.

STAINLESS STEEL FABRICATION NOTES:

1. FABRICATION SHOULD ONLY BE PERFORMED IN AN AREA, AND WITH EQUIPMENT, THAT IS NOT CONTAMINATED WITH FERROUS METAL.
2. ALL EDGES TO BE DEBURRED AND FREE OF SHARP PROTRUSIONS.
3. ALL STRUCTURAL WELDS TO AS 1554.
4. ALL STANDARD SECTIONS TO BE DOCKED AT 90° UNLESS STATED OTHERWISE.
5. CERTIFICATES OF CONFORMITY MUST ACCOMPANY ANY MATERIALS USED IN THE FABRICATION PROCESS.

PARTS LIST				
NO.	TITLE	MATERIAL	DRAWING #	QTY.
1	Frame	316 S/S Bead Blasted Electropolished	-	1
2	Spigot	Mild Steel HDG	05-233	4
3	M12x25 Button Socket Pin	304 Stainless Steel	-	16
4	14g x 32 Pan Head Square Socket woodscrew	304 Stainless Steel	-	64
5	Waterside Seat Slaf	Spotted Gum	05-233	16

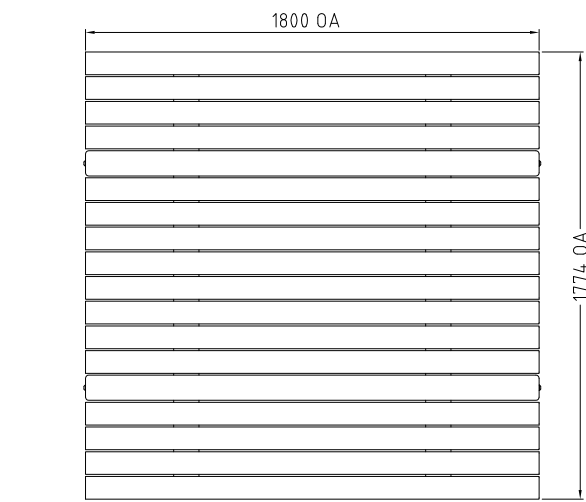

TOP VIEW

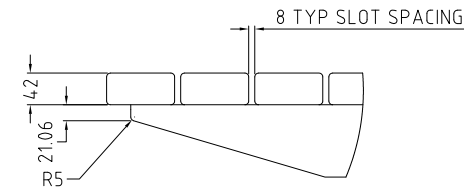

DETAIL B

GCCC Logo location -
 Typical on both sides of platform
 on one leg only.
 Refer GCCC Std Dwg. No.05-538

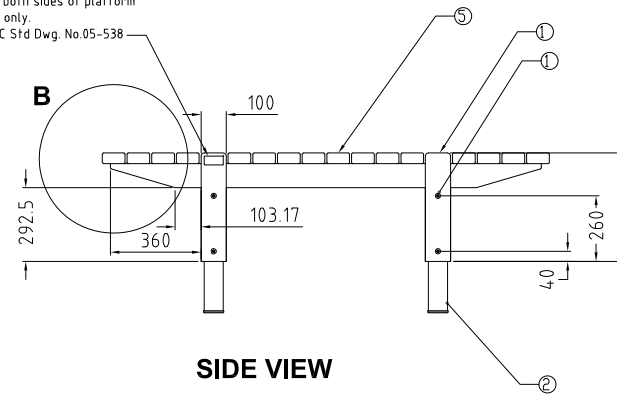

SIDE VIEW

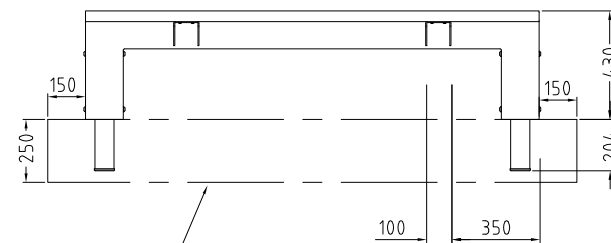
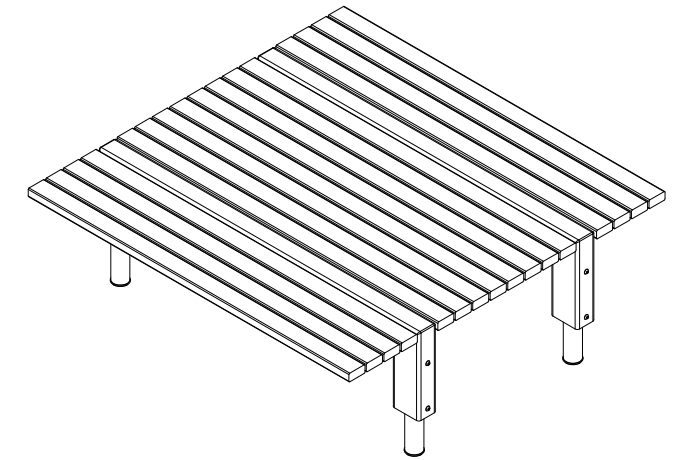

FRONT VIEW

Dashed line represents concrete pad.
 Refer GCCC std dwg no. 05-539

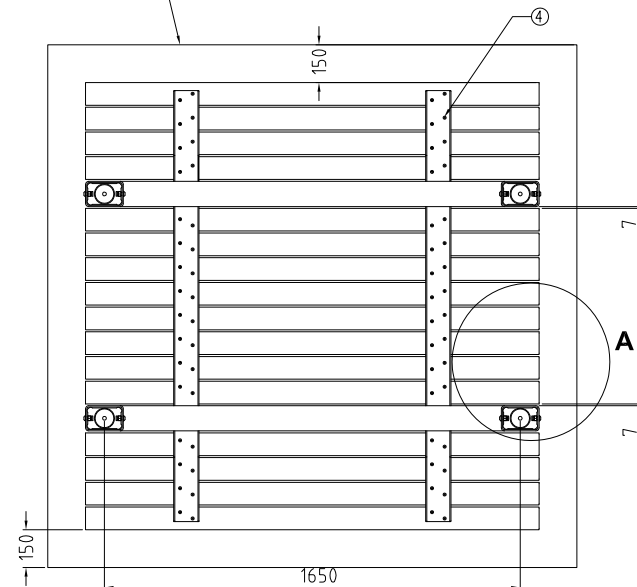

BOTTOM VIEW

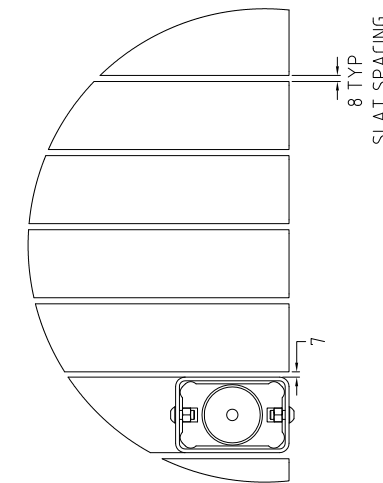

DETAIL A

NOTE:-
 THIS DRAWING HAS BEEN SOURCED FROM HUBB STREET EQUIPMENT. THIS DRAWING IS NOT DRAWN TO GCCC STANDARD T.P.R GUIDELINES.



Gold Coast City Council

GOLD COAST CITY COUNCIL
 PO BOX 5042
 GOLD COAST MC 9729

THIS DRAWING IS NOT TO BE AMENDED WITHOUT REFERENCE TO STANDARDS COMMITTEE

CONTROLLED DOCUMENT

DO NOT SCALE TAKE FIGURED DIMENSIONS ONLY

STANDARD DRAWING

MICROFILMED

DRAFTING BY
TECHNICAL SERVICES BRANCH

PASSED - COORDINATOR OPEN SPACE ASSETS
 SIGNED: CAMERON TAYLOR DATE: 6/12/12

APPROVED - MANAGER PARKS & RECREATIONAL SERVICES
 SIGNED: RON JACOBS DATE: 6/12/12

WATERSIDE SUITE - PICNIC PLATFORM

STANDARD DRAWING No.

13-05-527

ISSUE

2013 EDITION

No.	AMENDMENT	APPROVED	DATE	ISSUED

THIS DRAWING HAS BEEN SOURCED FROM HUBB STREET EQUIPMENT DRAWING NUMBERS 7432.901 TO 7432.938