

VALVE MOUNTING SPIGOT
1 REQUIRED

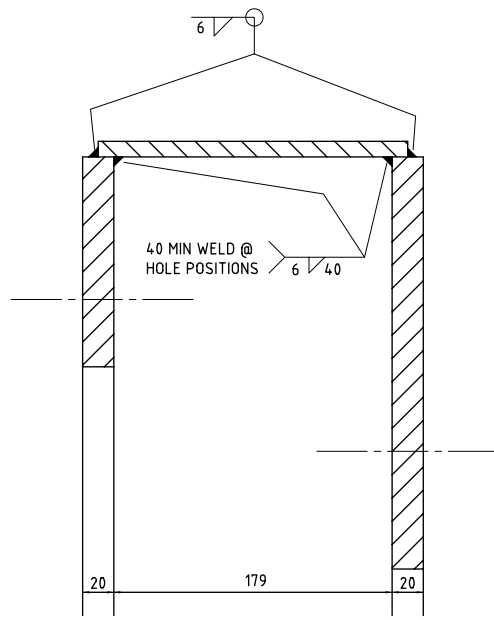
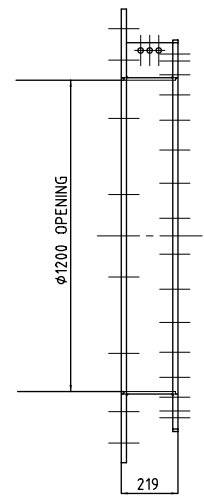

SECTION B

NOTES

1. WELDING TO CONFORM TO AS1554.6 CAT SP.
2. WELDING ELECTRODES TO CONFORM TO ANSI/AWS A5.9.
3. GATE SURFACES ROUGHNESS SHALL NOT EXCEED 1.6m ISO4288.
4. ALL SHARP EDGES TO BE REMOVED AND HOLES TO BE DE-BURRED.
5. ALL COMPONENTS SS316 EXCEPT BODY LINER, SPACER PLATES & SEALS LIMIT NUT AND STEM COVER.
6. COAT ALL EXTERNAL FACES OF FLANGE & VALVE COVERED BY BENCHING WITH ENVIROPEEL OR EQUAL.

HYDRAULIC DATA/PERFORMANCE

1. MAXIMUM PRESSURE: 15m HEAD (OR AS SPECIFIED).
2. GATE LEAKAGE: MAXIMUM PRESSURE 4.0mL/MIN/25mm OF DIAMETER.
3. DIRECTION: ON SEATING ONLY.
4. CLOCKWISE CLOSING.

Ø1200 KNIFEGATE VALVE

TO SUIT 48" FLANGE: AS 4087-1993 (CLASS 14/16)

SECTION A
225 LONG MOUNTING SPIGOT
16 HOLES Ø24 ON A Ø1630 PCD
M20x240 ANCHORS c/w 2N+2W



THIS DRAWING IS NOT TO BE AMENDED WITHOUT REFERENCE TO STANDARDS COMMITTEE					CONTROLLED DOCUMENT	DO NOT SCALE TAKE FIGURED DIMENSIONS ONLY	DRAWN BY G.C.W 08/07/08 PASSED D. HAYMAN 08/07/08 APPROVED R. WENT 08/07/08
No.	AMENDMENT	APPROVED	DATE	ISSUED			

STANDARD DRAWING

TRUNK SEWER
KNIFEGATE VALVE

MICROFILMED
STANDARD DRAWING No.
08-07-143
ISSUE
2008 EDITION

GOLD COAST CITY COUNCIL
PO BOX 5042
GOLD COAST MC 9729